

MECHANICAL ENGINEERING ACTIVITIES

The blower is intended for suction of air or aggressive gases and subsequent transport. Transport of gases is free of oil. The aggregates are intended for nuclear power plants and used in various technologies (gas conditioning systems – hydrogen combustion, radiation monitor, etc.).

Blower Aggregate ICE85 AE

DESCRIPTION OF BLOWER

The blowers are of the Roots type with two three-lobe rotors whose movement is mutually joined by a synchronizing gearing with the same number of teeth. This secures contactless movement of rotor lobes. A suction branch and a discharge branch run into between axes of the rotors.

Function

Rotation of the rotors in a specified direction sucks gas in and closes it between two rotor lobes and the blower case (transport space) and air is transported from the suction branch to the discharge branch, i.e., alternatively on both rotors. Compression of gas occurs downstream of the blower (it is the blower with external compression). A pressure difference value is given by a pressure difference between a discharge flange and a suction flange of the blower; clearances between rotors and between rotors and the blower case influence the blower efficiency. Transfer of air mass from the working space to the discharge branch occurs six times during one revolution of the rotors.

Resulting gas pulsation is sextuple of revolution frequency. The blower output can be controlled by change of speed (through change of a belt transmission value, by using a pole-changing electric motor, a frequency converter, etc.).

STRUCTURAL DESIGN OF BLOWER

It is a non-standard design of the blower that differs from the standard design in construction of seals, material of main parts (austenitic steel) and a condensate discharge hole. Sealing of the transport space and the output shaft is performed by a Trelleborg or a Garlock rotating seal. In addition, tightness of seals is ensured by filling them with nitrogen at pressure higher than working pressure of the blower (0.22-0.25 MPa abs.). The blower can also be in operation without limitations when the seals are not filled with nitrogen. The blower body is equipped with precast anti-pulsation grooves and a trapezoidal suction port for reduction of pulsation and noise. This considerably reduces the total level of noise and pulsation in piping and also vibration of the suction and the discharge piping and valves included in it to a minimum.

Material and designation of main parts:

- case (body and two flanges) – cast steel with quality of 10CH 18N9L (GOST) or 422931 according to ČSN
- rotors (dynamically balanced), seal bushes and rings – material quality of 1.4541 (Werkstoff number) or ČSN 17248 (or equivalent)
- helical gears – cemented, hardened and ground steel, steel quality according to ČSN 14220 or ČSN EN, 16MnCr5 (or equivalent)
- bearings – 3205 A (2 pcs), 6205 (1 pc) and NJ 2205 EC (1 pc), manufacturer SKF.

The body has standard dimensions for connection of suction and discharge pipes (DN65, PN10).

DESCRIPTION OF BLOWER AGGREGATE

The blower and an adjustable plate forming a motor bed are attached to the basic frame of the welded construction. This enables to comfortably adjust the motor and tighten a belt without additional vibrations. Use of a toothed belt secures the permanent adjustment without necessity of its retightening during operation, and a higher efficiency ($\xi=0.97$) of power transfer from the electric motor than that with V-belts ($\xi=0.93$). The frame is isolated from the foundation by means of rubber springs. The drive is realised by an electric motor (with a soft starter) with an above – mentioned toothed belt. A cover of belts is of a steel structure. Nitrogen enters the seals through stainless pipes with Legris screw unions. Direction of rotation is marked on the blower.

The blower aggregate is equipped with a screen on the suction side for filtration of a mixture of gases being sucked in, with 0.1×0.1 mm mesh size. Pressure nitrogen enters the seals through a Zander G03 XP PN16-40 microfilter with filtration efficiency of 99.9999 % (max. 0.5 mg/m^3). Maximum size of impurities passed through the filter is 0.01 micron.

The aggregate is further equipped with two manometers with shut-off valves monitoring a pressure loss of the suction screen and with a thermometer of a transported mixture of gases at discharge.

BLOWER AGGREGATE OUTPUT PARAMETERS

- specified for medium to be transported (air or gaseous mixture) with temperature of $40 \text{ }^\circ\text{C}$ and pressure difference of 50 kPa)

Blower shaft input	2.2 kW
Aggregate input	2.7 kW
Electric motor power	4 kW (3 kW is sufficient for required parameters)
Output	65 – 85 m^3 per hour
Temperature at discharge	140°C
Blower speed	2,850 rpm *
Suction-discharge pressure difference	50 kPa

* blower speed is for information only

Electric motor: 1LE1001-1BA2, 4 kW, 2,950 rpm (increased efficiency) or 1LA7113-2AA, 4 kW, 2905 rpm – 4 kW motor is selected in accordance with the present motor in order that as few changes as possible occur. 3RW30 16-1BB04 (4 kW, 400 V) soft starter.

LIMITING OUTPUT PARAMETERS OF BLOWER

Max. overpressure	180 kPa abs.
Max. underpressure	50 kPa abs.
Max. pressure ratio (inlet/outlet)	2
Max. outlet temperature	160°C
Inlet temperature	$\sim 80^\circ\text{C}$ (depends on working pressure difference)
Max. speed	4,500 rpm
Min. speed	It is subject to pressure and max. permissible
Max. torque	20 Nm
Permissible radial load of drive shaft	800 N

The blowers and the blower aggregates are tested in the factory. Types of tests and inspections performed are specified in the Inspection and Test Plan. Acceptance tests are performed in a company's testing room of the manufacturer.

RELATED REGULATIONS AND STANDARDS

- General:** SÚJB Decree No. 132/2008 Coll., Law No. 22/1997 Coll., as subsequently amended
The Czech Republic Government Decrees Nos. 170/1997, 168/1997, 169/1997
- Standards:** ČSN EN ISO 9001, EN 292-1, EN 292-2, EN 294, EN 349, EN 563, EN 3864, EN 1012-1,
N 1012-2, EN 5388, EN 60204-1, ISO 5167-1, ČSN EN ISO 17050-1.

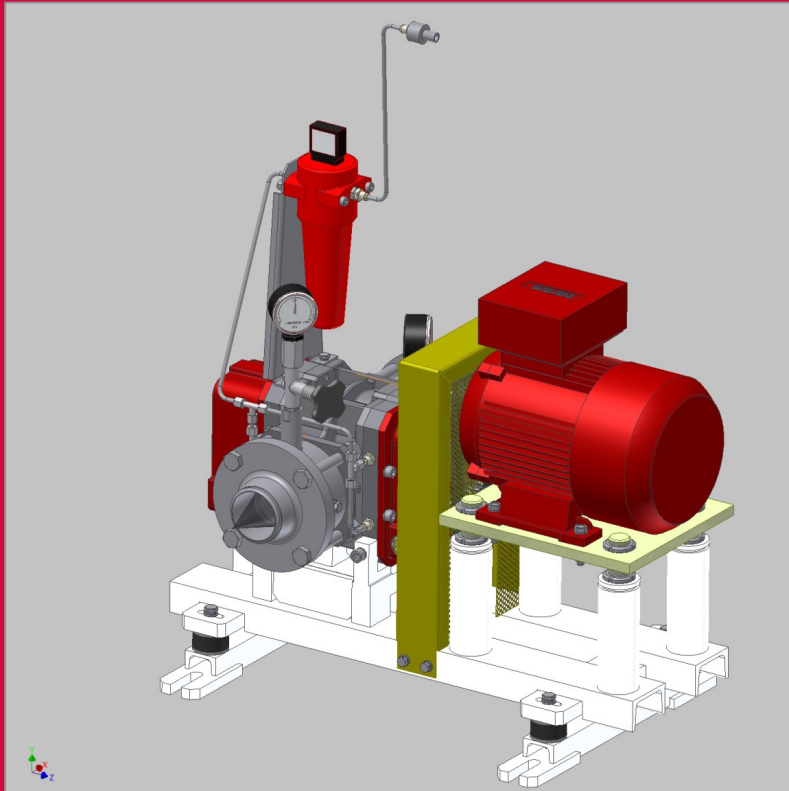

ICE85 AE

View from the suction side with a filter of gas being sucked in and a vacuum manometer with a shut-off cock.

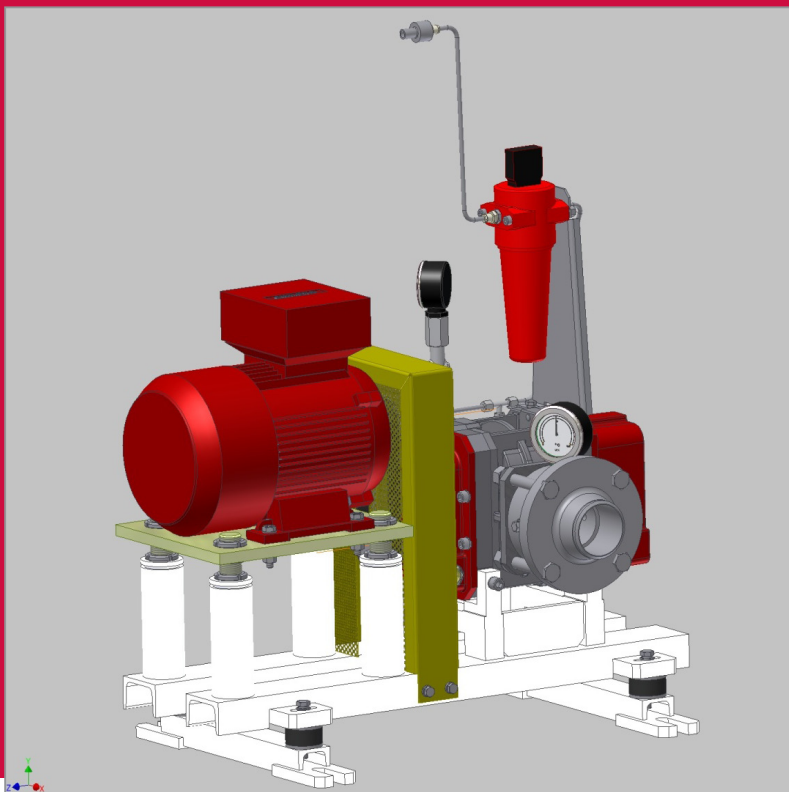

View from the discharge side with an analog thermometer of gas in the discharge pipe.

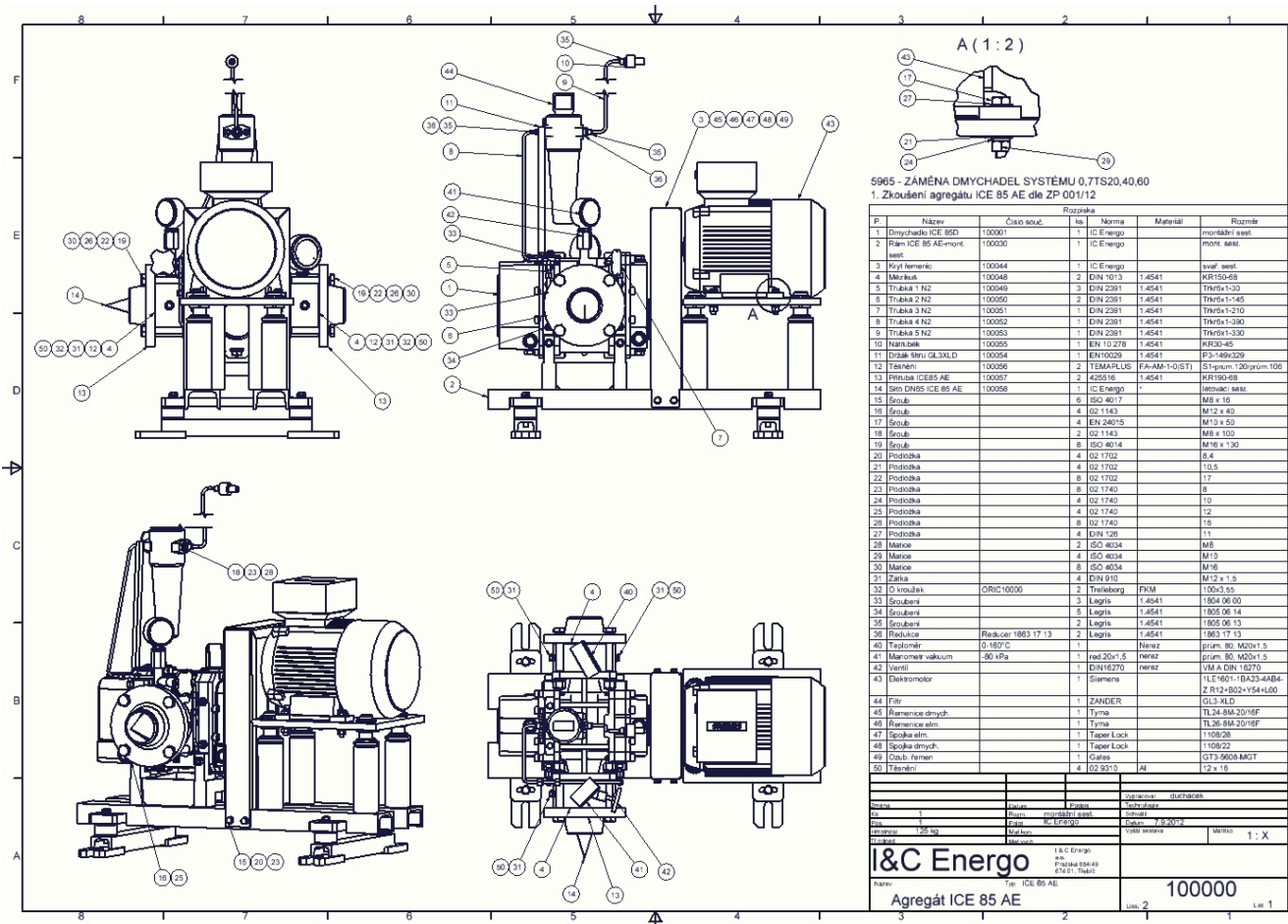

I&C Energo a.s.

Leading supplier of comprehensive services in the area of command and control, industrial information systems and electrical systems and mechanical engineering activities with a strong history in the nuclear power sector.

- Year of inception: 1993
- Value of registered capital: €5.47 million
- Legal form: Joint-stock company
- Company identification: ID Number: 49433431,
Tax ID Number: CZ49433431
- Trade connections: P +420 568 413 111
F +420 568 413 999
E obchod@ic-energo.eu
www.ic-energo.com
- Seat of the company: Pražská 684/49
674 01 Třebíč
Czech Republic
- Integrated management system: ISO 9001, ISO 14001, ČSN OHSAS 18001
- Company is registered by the Regional Court in Brno, Section B, File No. 4153.